



Now Powered
by LightField™

PIXIS: 100 1340 x 100



The PIXIS series from Princeton Instruments (PI) are fully integrated, low noise cameras with a 1340 pixel format designed for quantitative scientific optical spectroscopy applications. Based on PI's exclusive XP cooling technology, PIXIS cameras offer thermoelectric cooling down to -80°C , with an all-metal, hermetically sealed design and the industry's only lifetime vacuum guarantee. High QE and ultra low-noise electronics make the PIXIS series of cameras ideal for demanding, low light applications such as Raman spectroscopy, photo- and electroluminescence, fluorescence and reflectance spectroscopy. Princeton Instruments' exclusive eXcelon™ technology delivers the highest sensitivity available from the deep UV to the NIR, while suppressing the etaloning that occurs in conventional back-thinned devices. Dual speed operation at 100 kHz or 2 MHz enables these cameras to be used for either long acquisitions or fast kinetic studies.

FEATURE	BENEFITS
eXcelon™ technology	Increases detector sensitivity while suppressing etalon interference fringes observed in the NIR with conventional back-illuminated devices
Permanent vacuum	Our all-metal brazed seals eliminate the outgassing that occurs with epoxy seals and allows us to offer the industry's only lifetime vacuum guarantee
Deep thermoelectric cooling	Low temperature operation minimizes dark current without the need for liquid nitrogen
Single fused silica vacuum window	Minimizes reflection losses from the UV to the IR; Optional AR coating and wedge windows are available
1340 x100 imaging array, 20 μm x 20 μm pixels	Proprietary format with 2 mm height for rapid spectral acquisition; 20 μm pixel size offers the optimal combination of high resolution with dynamic range
Optional UV phosphor coatings	Enhances sensitivity throughout the UV to below 200 nm (not available for eXcelon cameras)
TTL input and output and shutter control	External control and triggering
100 kHz and 2 MHz digitization rates	Choose low speed digitization for low noise or high speed for fast spectral acquisition
Dual amplifiers with software-selectable system gains	High sensitivity amplifier reduces read noise floor for weak signals while a high capacity amplifier increases dynamic range
USB2.0 data interface	Plug-and-play operation with desktops or laptops; Optional fiber optic interface for remote operation
LightField™ for 64-bit Windows 7 or WinSpec for 32-bit Windows OS	Flexible software packages for data acquisition, display and analysis. LightField offers intuitive, cutting edge user interface, IntelliCal™ and more
PICAM/PVCAM SDKs	Universal programming interfaces

Applications:

Raman Spectroscopy, Absorbance,
Emission, Fluorescence and
Reflectance Spectroscopy

SPECIFICATIONS

	 PIXIS: 100BR_eXcelon	PIXIS: 100BR	 PIXIS: 100B_eXcelon	PIXIS: 100B	PIXIS: 100F
Features	Back-illuminated, deep depletion CCD with eXcelon technology. Highest average QE from the UV to the NIR with negligible etaloning.	Back-illuminated, deep depletion CCD. High QE in the NIR with minimal etaloning.	Back-illuminated CCD with eXcelon technology. Enhanced sensitivity in the UV and the NIR with low etaloning.	Back-illuminated CCD. Highest QE in the visible with low dark current. Subject to etaloning in the NIR.	Front-illuminated CCD. Affordable technology for moderate light level applications. No etaloning.
Dark current @ -80°C (e-/p/sec)	0.03 (typical)	0.03 (typical)	0.001 (typical)	0.001 (typical)	0.0008 (typical)
CCD format	1340 x 100, 20 x 20 μm pixels with 100% fill factor				
Imaging area	26.8 x 2.0 mm (optically centered)				
Optical mount	Princeton Instruments' Acton spectrometer adapter with optional shutter				
Deepest cooling temperature	-80°C guaranteed				
Thermostating precision	±0.05°C				
Cooling method	Thermoelectric air or liquid cooling; CoolCUBE II, a compact room temperature coolant circulator, is available for vibration sensitive environments				
Spectrometric Well Capacity: High Sensitivity High Capacity	300 ke- (typical), 250 ke- (min) 1 Me- (typical), 750 ke- (min)				
ADC speed/bits	100 kHz/16-bit and 2 MHz/16-bit				
System read noise @100 kHz @2 MHz	Front-illuminated 2.5 e- rms (typical), 4 e- rms (max) 10 e- rms (typical), 15 e- rms (max)		Back-illuminated 3 e- rms (typical), 5 e- rms (max) 11 e- rms (typical), 16 e- rms (max)		
Vertical shift speed	< 15 μsec/row (programmable)				
Non-linearity	< 1% @ 100 kHz				
Software selectable gains	1, 2, 4 e- (high sensitivity); 4, 8, 16 e- (high capacity); available at all speeds				
Operating systems supported	Windows XP/7 (32-bit), Windows 7 (64-bit) and Linux				
Data interface	Gigabit Ethernet				
I/O signals	Two MCX to BNC connectors for programmable frame readout, shutter, trigger in				
Operating environment	+5 to +30°C, non-condensing atmosphere				
Certification	CE				
Dimensions / Weight	16.3 cm (6.43") x 11.8 cm (4.65") x 11.4 cm (4.48") (L x W x H) / 2.27 kg (5 lbs)				

All specifications are subject to change.

SPECTRAL RATE

@ 100 kHz	Full Vertical Binning (FVB)	70 fps
@ 2 MHz	Full Vertical Binning (FVB)	750 fps
@ 2 MHz	(0.2 mm high)	1300 fps

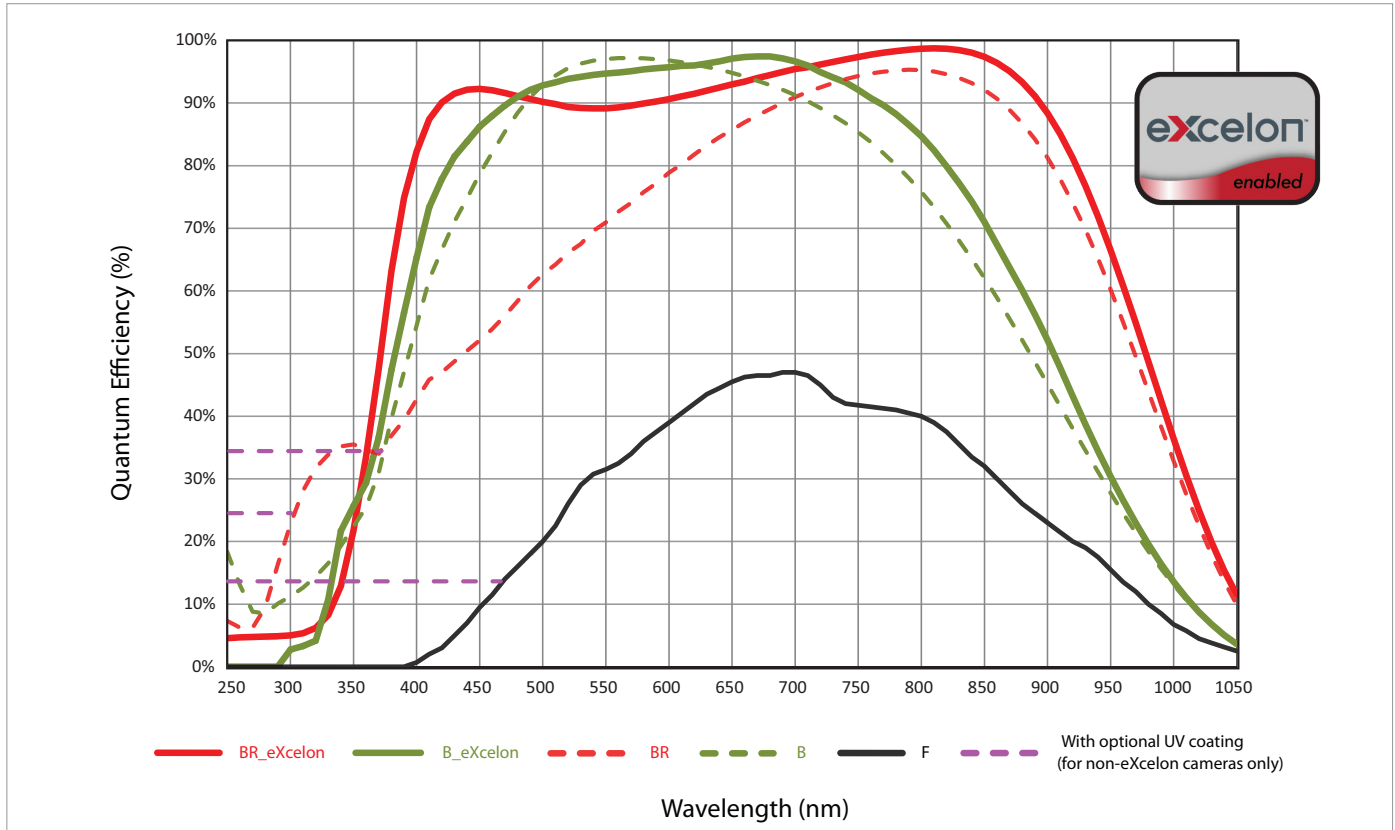

NOTE: Graph shows typical Quantum Efficiency (QE) data measured at + 25°C. QE decreases at normal operating temperatures. For the best results for your application, please discuss the specific parameters of your experiment with your sales representative.

VACUUM WINDOW AR COATINGS

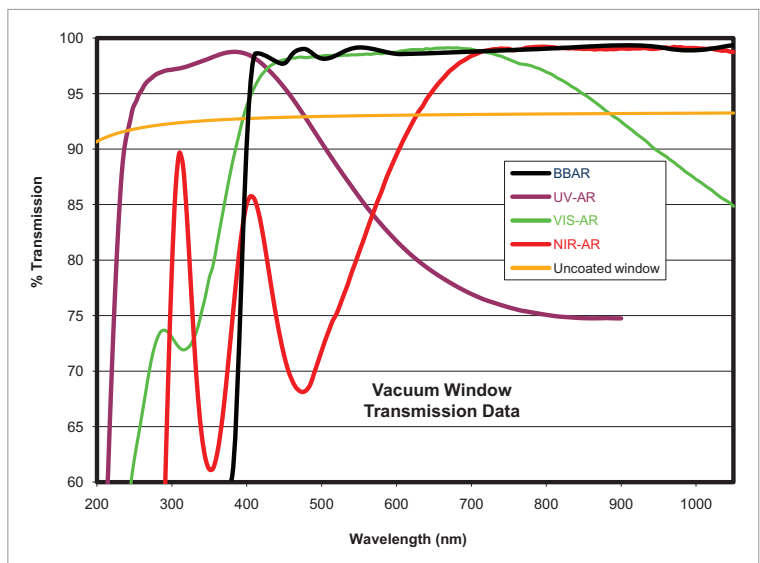

NOTE: Standard anti-reflection (AR) coatings shown. Custom AR coatings and wedge window options are also available. Contact your local sales representative for more information.

Data taken with white light source through a monochromator, comparing etaloning performance of eXcelon vs. back-illuminated CCDs.

Back-illuminated



Back-illuminated_eXcelon

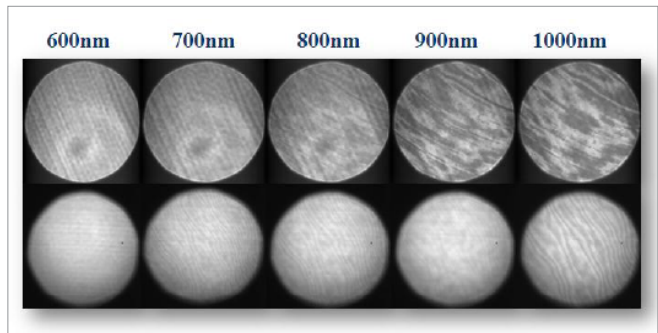

QE Improvement (B_eXcelon vs. B)

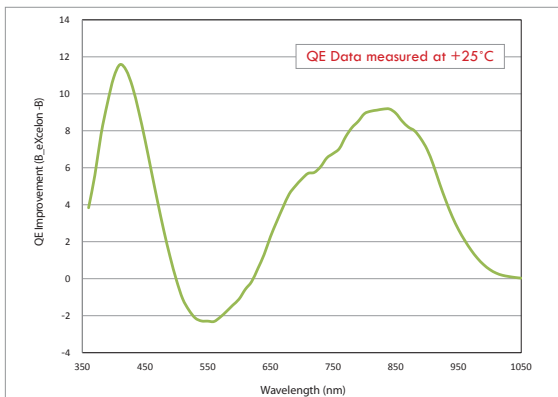

B_eXcelon provides superior QE over the standard back illuminated ("B") version in the UV-NIR range.

Etalon Oscillations (B_eXcelon vs. B)

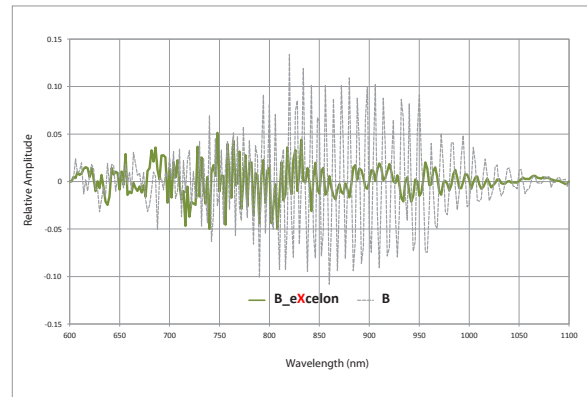

B_eXcelon provides significantly lower etaloning (unwanted fringes) compared to standard back illuminated ("B") version.

QE Improvement (BR_eXcelon vs. BR)

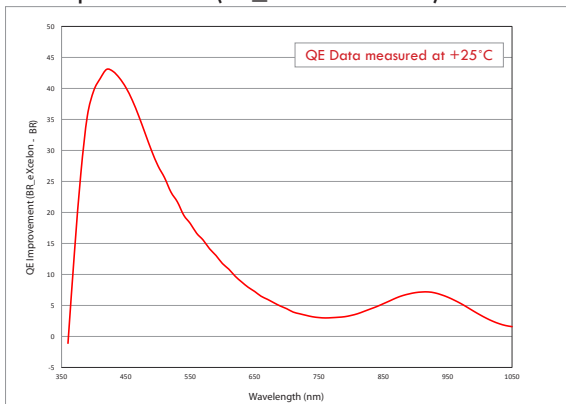

BR_eXcelon provides superior QE over standard back illuminated deep depletion ("BR") version over the entire UV-NIR range.

Etalon Oscillations (BR_eXcelon vs. BR)

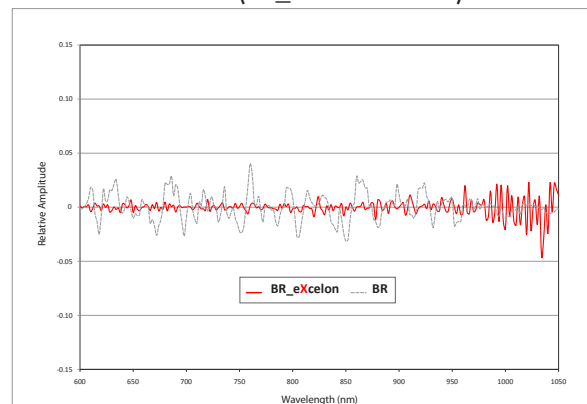

BR_eXcelon eliminates much of the residual etaloning observed in the standard back-illuminated deep depletion ("BR") version.

PIXIS DRAWINGS (AIR COOLED)

PIXIS with Spectroscopy Mount

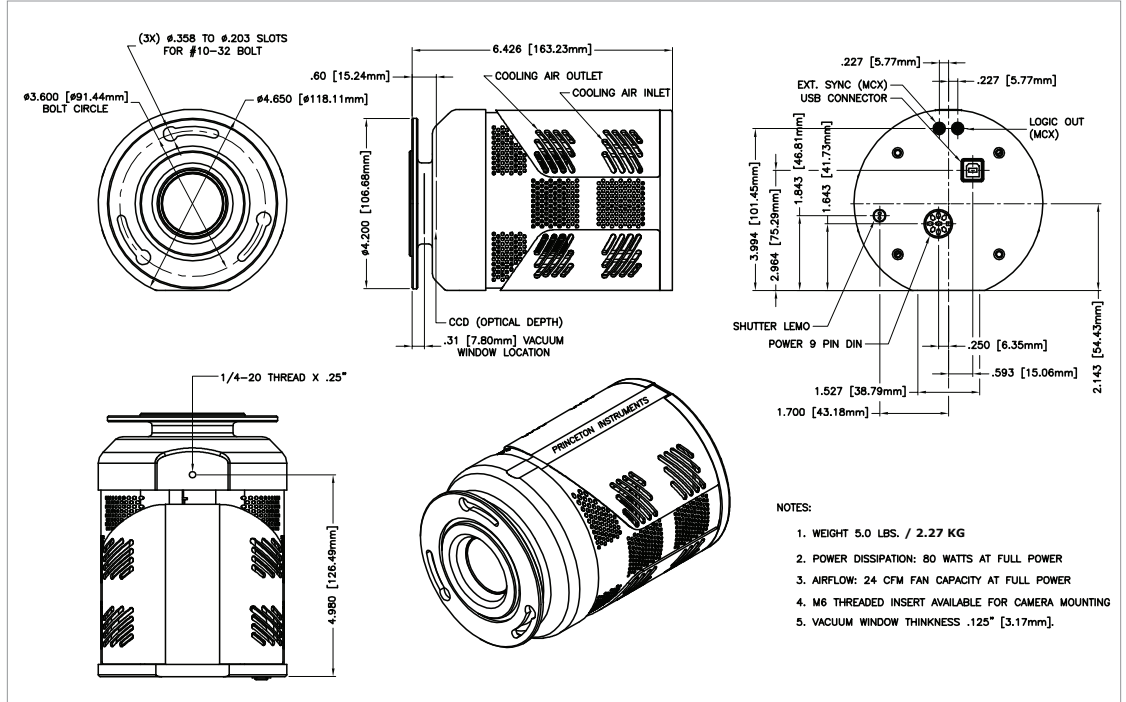

PIXIS with Spectroscopy Mount; with Shutter

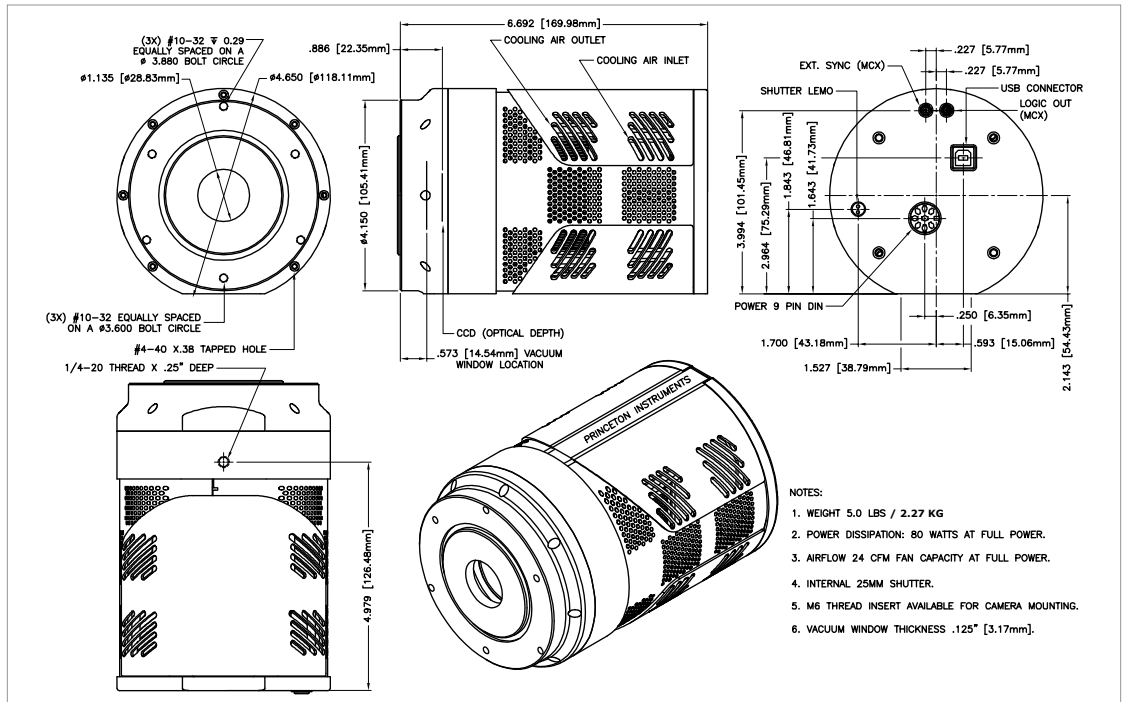

PIXIS DRAWINGS (LIQUID COOLED)

