



2D-OMA V: 320

The 2D-OMA V: 320 from Princeton Instruments is the world's first, scientific grade InGaAs camera for low-light NIR imaging applications. The camera uses a 320 x 256 InGaAs array with response up to 1.7 μ m. The detector is cryogenically cooled to minimize thermally generated noise and to improve signal-to-noise ratio for the most demanding NIR applications. It offers 16-bit digitization and > 50 frames per second for outstanding dynamic range and speed. Software selectable gains allow it to be tailored to applications requiring high dynamic range or high sensitivity.

FEATURE	BENEFITS
320 x 256 InGaAs array	Ideal for imaging in the NIR region
30 x 30 μ m pixels	Good spatial resolution
Response from 0.9 to 1.7 μ m with >80% peak quantum efficiency	Excellent NIR sensitivity for demanding imaging applications
Cryogenic cooling	Minimizes dark noise and allows extended integration times Special "cold shield" limits the ambient background for improved contrast
Software-selectable amplifiers	Provides choice of superior sensitivity or dynamic range
Electronic shutter	Provides integration times from 1 μ sec to many minutes
High frame rate	Provides 53 frames/second at 5-MHz digitization
C-mount or F-mount	Standard lens interface compatible with numerous lenses and microscopes. (Spectroscopy mount available)
Sapphire window	Single sapphire window in the optical path for high light throughput
PCI interface	Industry standard for fast data transfer over long distances
WinView and WinSpec	Offers powerful, easy-to-use set of Windows GUI controls Automates data acquisition, background and flat field corrections and display
SITK™ for LabVIEW™	Easy integration into complex experimental setup
PVCAM® Interface	Renowned camera interface for powerful custom programming

Applications:

Nanotube fluorescence, emission, absorption, non-destructive testing and singlet oxygen detection

2D-OMA V: 320 SPECIFICATIONS

CCD image sensor	2D InGaAs focal plane array
CCD format	320 x 256 imaging pixels
Pixel size (μm)	30 x 30 μm

	Minimum	Typical	Maximum
Pixel well capacity (ke-)			
low gain		2500	
high gain		180	
System read noise (e-)		50 (High Gain)	
Nominal gain (e-/count)			
low gain		60	
high gain		3	
Response nonlinearity			
low gain			<1%
high gain			<5%
Response nonuniformity			<10%
Dark current (e-/p/sec)		5000 @ -100°C	

Blemish specification	Grade A: <1% defects, For detailed blemish specifications, contact factory
Digitization (bits)	16
Scan rate (MHz)	1, 5
Frame rate*	53 fps
Cold shield	f#/2.8
Minimum exposure time (msec)	1
Window material	Sapphire (AR coated)
Thermostating precision	$\pm 0.05^\circ\text{C}$ across entire temperature range
Operating temperature	-25 to -100°C

NOTE: All specifications are subject to change.

* No binning allowed

QE Curve

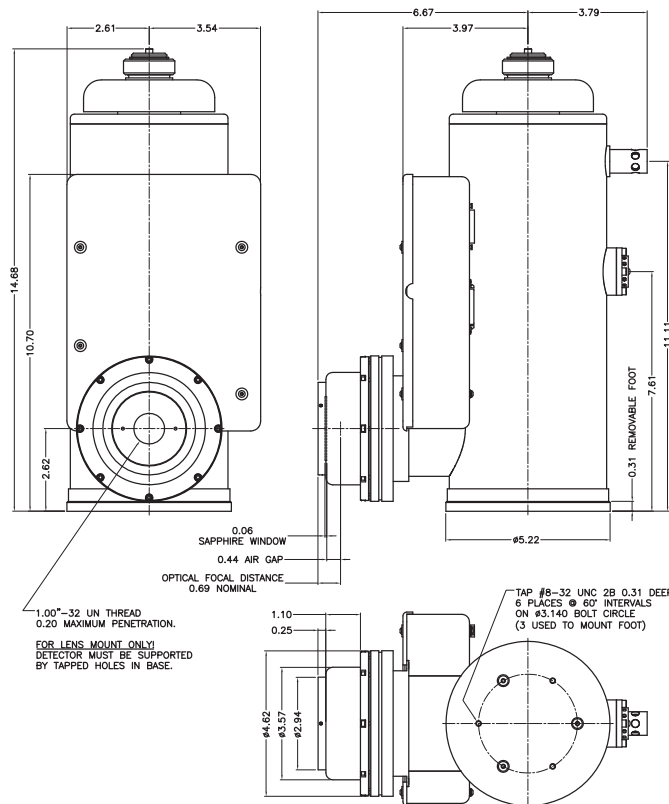
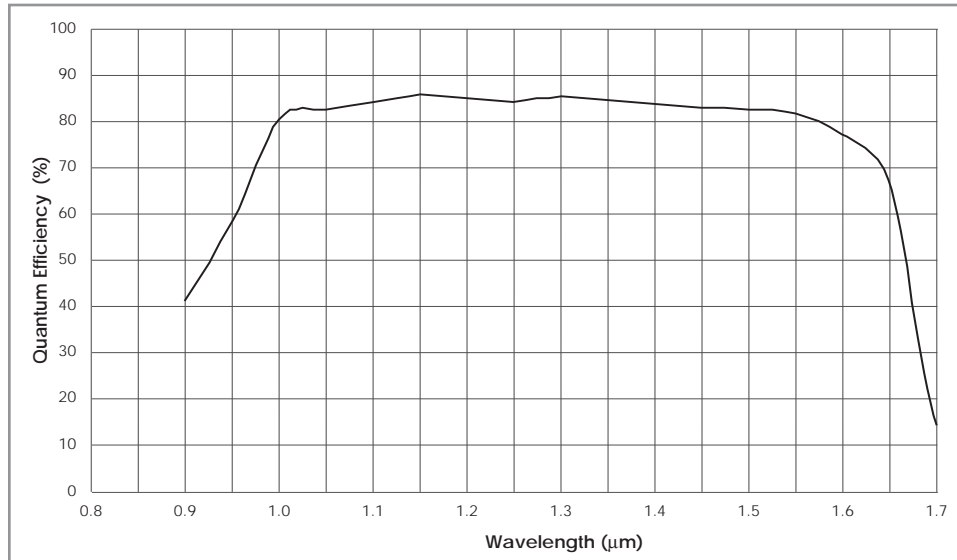

NOTE: All dimensions are in inches.