



PI-LCX: 1300

1340 x 1300 imaging array | 20 x 20 μm pixels



The PI-LCX: 1300 from Princeton Instruments is a high-sensitivity, high-resolution camera system designed for very low X-ray flux imaging and spectroscopy. With 20 x 20 μm pixels and 100% fill factor, this system provides high spatial resolution. A thin beryllium window in front vacuum seals the unit for deep cooling, protects the CCD, and reduces background by filtering low-energy X-rays. The thermoelectrically cooled option delivers maintenance-free operation, whereas the LN-cooled option provides extremely low dark current for long exposures. The software-selectable gains, output amplifiers, and readout speeds offer users highly flexible configuration capabilities to optimize system performance.

Applications: X-ray Spectroscopy, X-ray Photon Correlation Spectroscopy (XPCS), X-ray Intensity Fluctuation Spectroscopy (XIFS), X-ray diffraction, X-ray lithography

Features

Benefits

1340 x 1300 imaging array 20 x 20 μm pixels	"Princeton Instruments exclusive" CCD ideal for imaging Optimal pixel size for maximum full well and high spectral resolution
Direct-detection technology	Provides very low x-ray flux imaging (photon counting) and high spatial resolution
Deep-depletion technology	Highest sensitivity
Dual-speed, 16-bit digitization	High-speed readout for rapid data acquisition Slow-speed readout for high sensitivity with wide dynamic range, high signal-to-noise ratio (SNR), and excellent energy resolution
Flexible binning and readout	Increases frame rate and SNR
Cryogenic cooling option (liquid nitrogen)	Allows long exposures and very low dark current
Thermoelectric cooling option	Allows maintenance-free operation
Software-selectable gains, readout speeds, and output amplifiers	Allows optimization of system performance (lowest noise to widest dynamic range)
"USB 2.0 interface" configuration	Seamless, plug-and-play connection to PC notebooks and desktops; Easy OEM integration
"PCI interface" configuration	Industry standard for fast data transfer over long distances
WinView and PVCAM®	Offers powerful, easy-to-use set of Windows® GUI controls Automates data acquisition, analysis, and display
Linux® drivers and SITK™ plug-in for National Instruments' LabVIEW™	Extends system utility

Readout Rates

Binning	@ 1 MHz	@ 100 kHz	@ 50 kHz
1 x 1	1.78 sec	17.46 sec	34.75 sec
2 x 2	0.74 sec	4.98 sec	9.14 sec
4 x 4	0.29 sec	1.46 sec	2.5 sec

CCD image sensor	Princeton Instruments exclusive; front-illuminated, scientific-grade, non-MPP, deep-depletion device				
CCD format	1340 x 1300 imaging pixels 20 x 20 μm pixels 100% fill factor 26.8 x 26.0 mm imaging area (optically centered)				
Grade	Grade 1				
	Minimum		Typical		Maximum
			low noise	high capacity	low noise high capacity
CCD read noise			2 e- rms	6 e- rms	4 e- rms 8 e- rms
System read noise @ 50 kHz digitization @ 100 kHz digitization @ 1 MHz digitization			4 e- rms 5 e- rms 8 e- rms	6 e- rms 10 e- rms 18 e- rms	5 e- rms 6 e- rms 6 e- rms 12 e- rms 10 e- rms 20 e- rms
Single-pixel full well	200 ke-		400 ke-		
Output amplifier	low noise 200 ke-	high capacity 800 ke-	low noise 250 ke-	high capacity 1 Me-	
Dark current @ -40°C operation @ -110°C operation			100 e-/p/s 11 e-/p/hr		200 e-/p/s 36 e-/p/hr
Deepest cooling temperature thermoelectric (air) thermoelectric (chilled water) cryogenic (liquid nitrogen)	-35°C -40°C -100°C		-40°C -45°C -110°C		
Outputs	Low-noise (high-sensitivity) or high-capacity amplifier; user selectable*				
Software-selectable gains	1.2 e-, 2.5 e-, 5 e- (low-noise mode) 2.5 e-, 5 e-, 12 e- (high-capacity mode)				
Nonlinearity @ 100 kHz	< 2%				
Dynamic range	16 bits				
Scan rates	"100 kHz / 1 MHz" or "50 kHz / 1 MHz"				
Thermostating precision	$\pm 0.05^\circ\text{C}$ across entire temperature range				
LN hold time	>25 hours				

Note: Specifications are subject to change. *Applies to thermoelectric head only.

Quantum Efficiency Curve

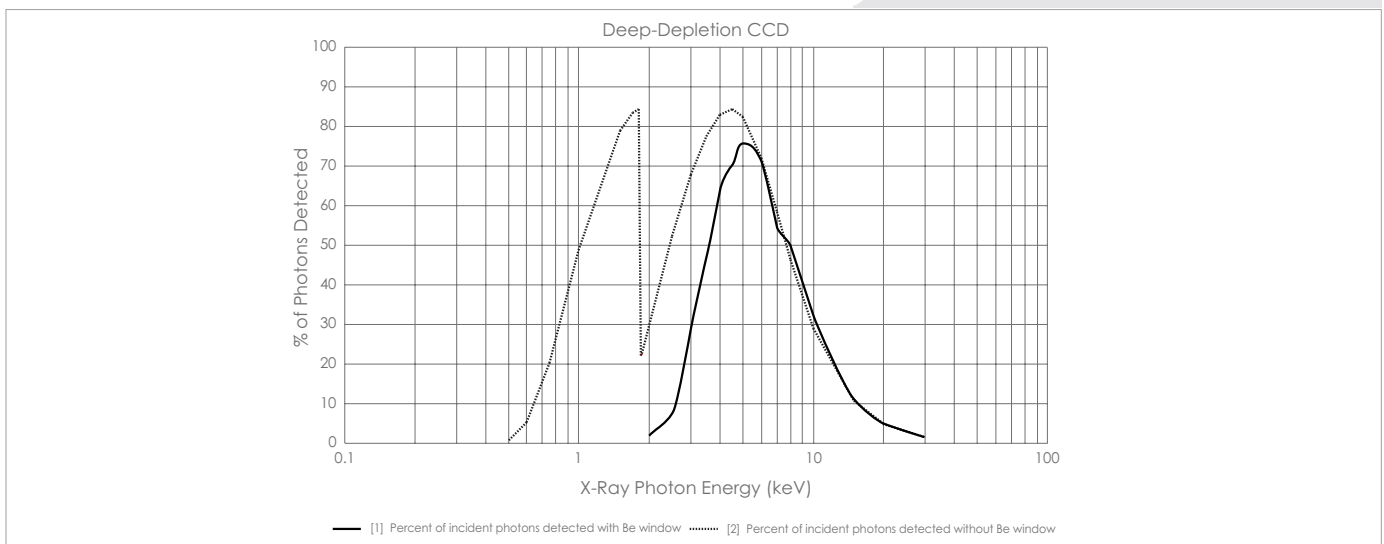

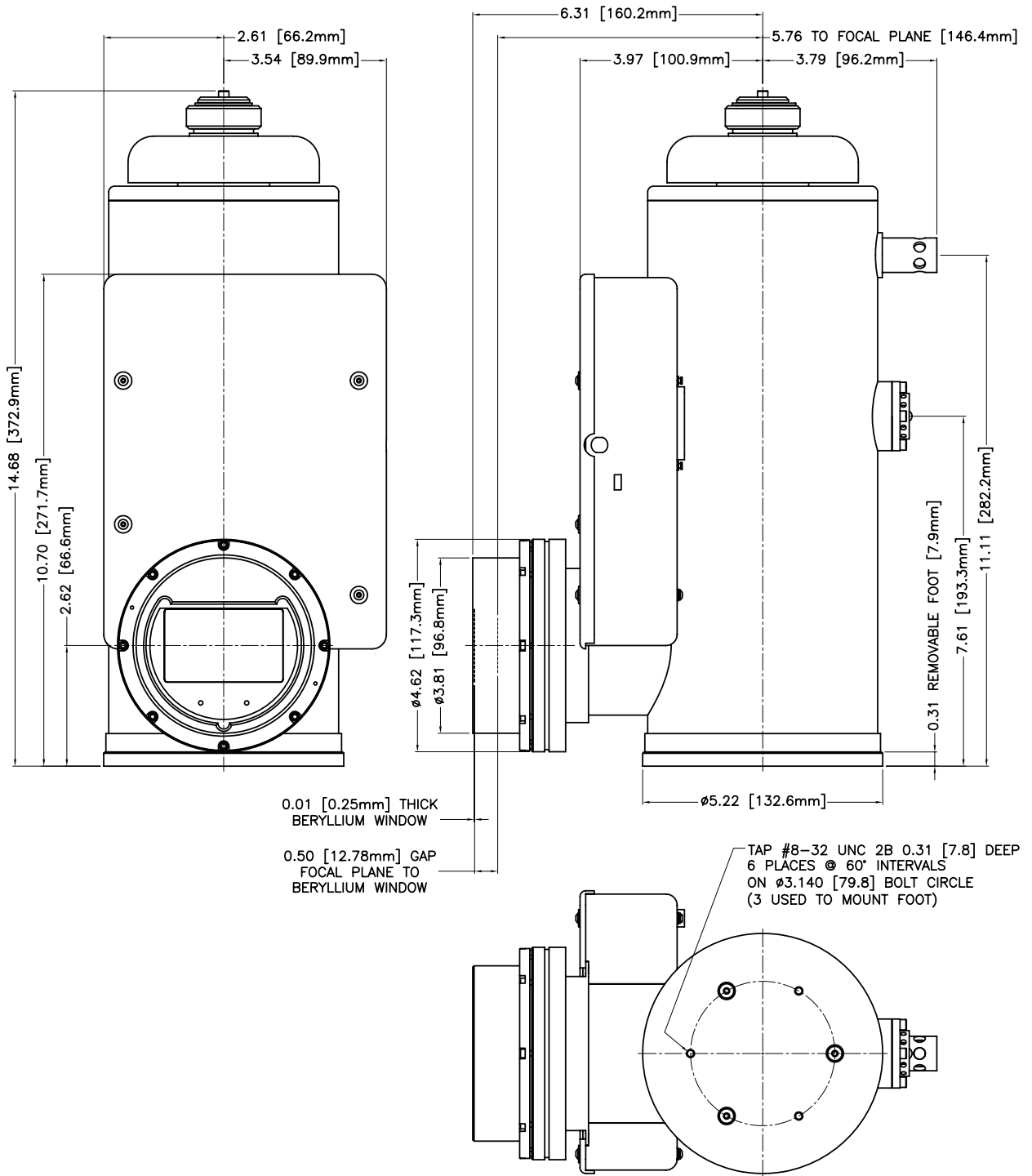

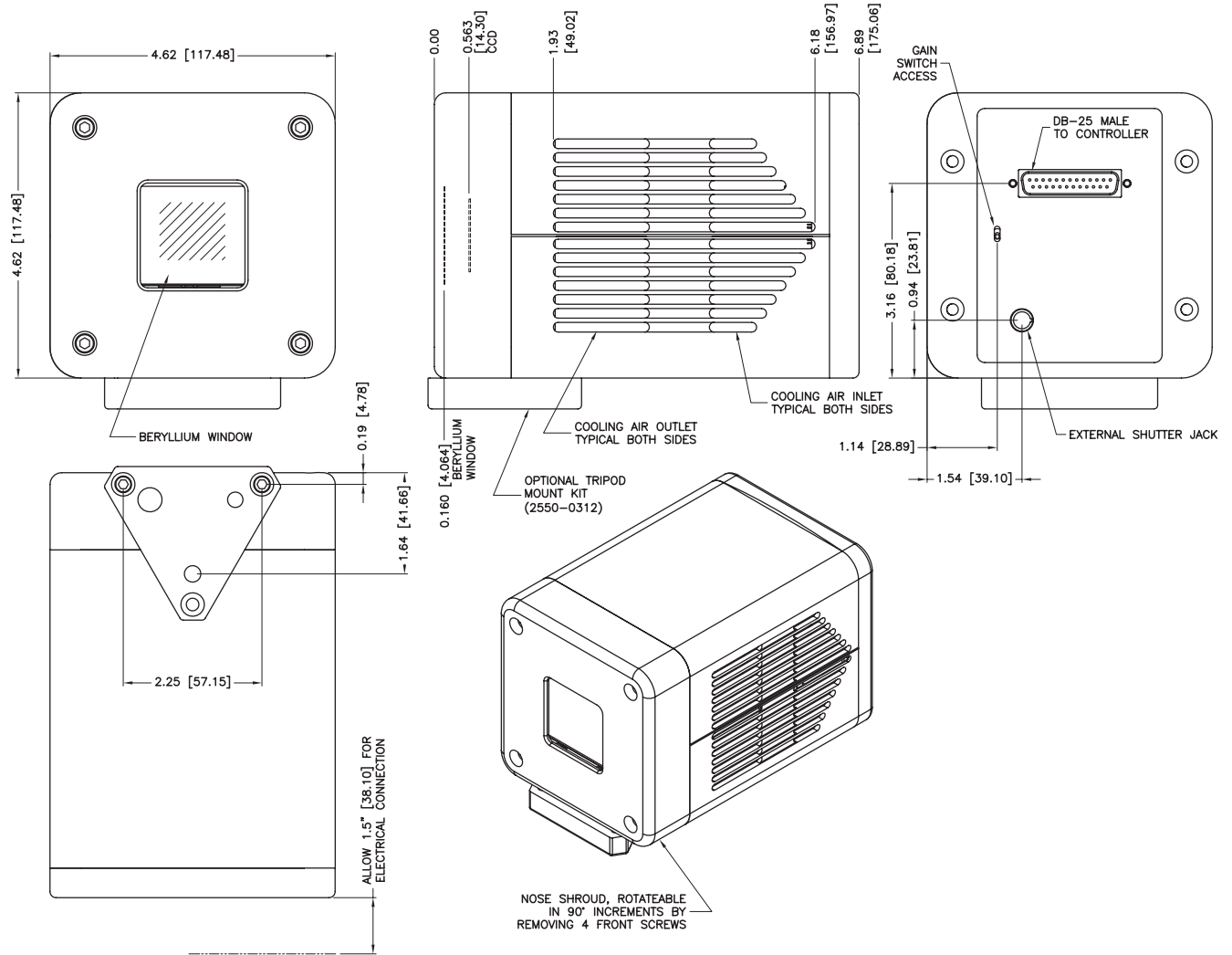

www.piacton.com

email: moreinfo@piacton.com

USA +1.877.4 PIACTON | Benelux +31 (347) 324989

France +33 (1) 60.86.03.65 | Germany +49 (0) 89.660.779.3

UK +44 (0) 28.38310171 | Asia/Pacific +65.6293.3130

China +86 135 0122 8135 | Japan +81.3.5639.2741