



Now Powered
by LightField™

PIoNIR: 640

The PloNIR: 640 from Princeton Instruments is the world's first scientific grade, deep-cooled, large format InGaAs camera for low-light scientific NIR imaging and spectroscopy applications. The camera uses a 640 x 512 InGaAs array with response from 0.9 μm to 1.7 μm . The detector is Peltier cooled to -80°C or below to minimize thermally generated noise and to improve signal-to-noise ratio for the most demanding NIR applications. It offers 16-bit digitization and low read noise for outstanding dynamic range.

FEATURE	BENEFITS
640 x 512 InGaAs array	High resolution imaging in the NIR region; Offers 4X more pixels over 320 x 256 sensor
20 μm x 20 μm pixels	High spatial resolution
Response from 0.9 μm to 1.7 μm with 85% (typical) peak quantum efficiency	Excellent NIR sensitivity for demanding imaging applications
Thermo-electric (Peltier) cooling	Minimizes dark noise and allows extended integration times without the need for liquid nitrogen; Built-in air or liquid cooling option for vibration sensitive environments
Integrated cold-shield	Special "cold shield" limits the ambient thermal background
Electronic shutter	Provides integration times from 1 μs to many minutes
C-mount	Standard lens interface compatible with numerous lenses and microscopes (spectrometer adapters available)
Fused silica window	AR coated, fused silica window for high transmission in NIR range
Gig E interface	Industry standard for fast data transfer over long distances, up to 50m
LightField™ for 64-bit Windows 7	Offers intuitive, cutting edge user interface; Provides data acquisition, defect correction, display and analysis
WinView and WinSpec for 32-bit Windows XP/7	Offers powerful, easy-to-use set of Windows GUI controls; Automates data acquisition, background and flat field corrections and display
SITK™ for LabVIEW™	Easy integration into complex experimental setup
PICAM (64-bit)/PVCAM (32-bit) software development kits (SDKs)	Universal programming interfaces for easy custom programming; Compatible with Windows XP/7 (32-bit) and Windows 7 (64-bit)

* PloNIR: 640 shown with lens, sold separately.

Applications:

Nanotube fluorescence, emission, absorption,
non-destructive testing and singlet oxygen detection

SPECIFICATIONS

CCD image sensor	2D InGaAs focal plane array
CCD format	640 x 512 imaging pixels
CCD image area	12.8 mm x 10.24 mm
Pixel size	20 μm x 20 μm
Pixel well capacity (ke-) High gain	40
System read noise (e-)	< 120 ¹ (High Gain)
Nominal gain (e-/count) High gain	1
Response nonlinearity High gain	< 2 %
Cooling temperature @ +20°C ambient	-80°C ² (guaranteed), -90°C ² (typical with Air +15°C liquid circulation)
Cooling method	Air only or liquid only, or a combination of air and liquid
Dark current (e-/p/sec)	480 (High Gain)
Blemish specification	Grade A: <2% defects For detailed blemish specifications, contact Princeton Instruments
Digitization	16 bits
Scan rate	2 MHz, 5 MHz, 10 MHz
Frame rate	22 fps @ 2 MHz 55 fps @ 5 MHz 110 fps @ 10 MHz
Binning and ROI	Software only
Cold shield	f#/1.5
Exposure time	< 10 μs to >10 sec
Window material	Fused silica (AR coated)
Thermostating precision	$\pm 0.05^\circ\text{C}$ across entire temperature range
Operating temperature	0°C to +30°C

¹ Measured with 1 μs exposure time

² Measured using room temperature target

All specifications are typical and are subject to change.

Sensor QE Curve

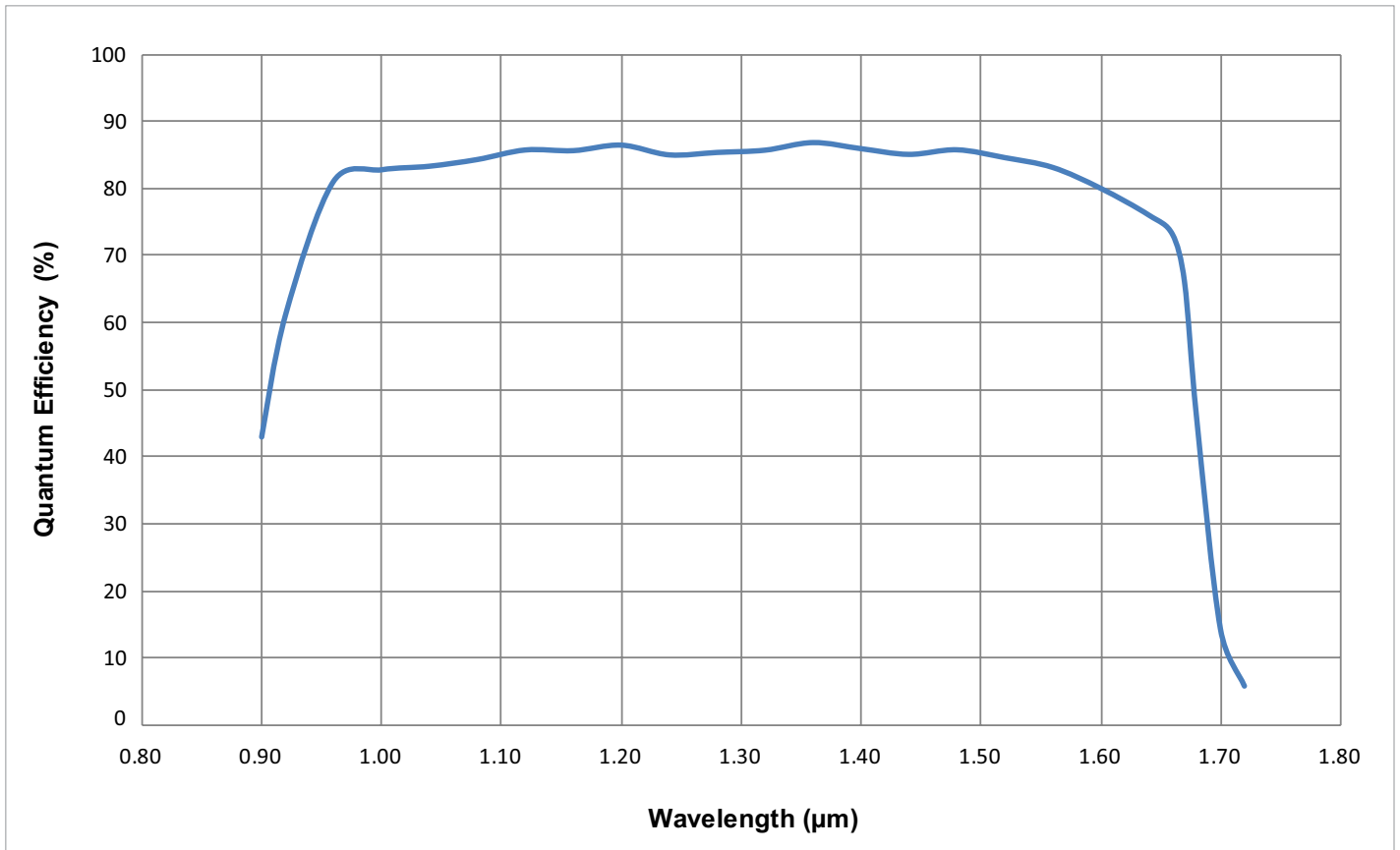

NOTE:

Graph shows typical Quantum Efficiency (QE) data measured at + 25°C. Longer cut-off wavelength shifts towards blue by 8nm per every 10°C of cooling.

Outline Drawing (C-mount)

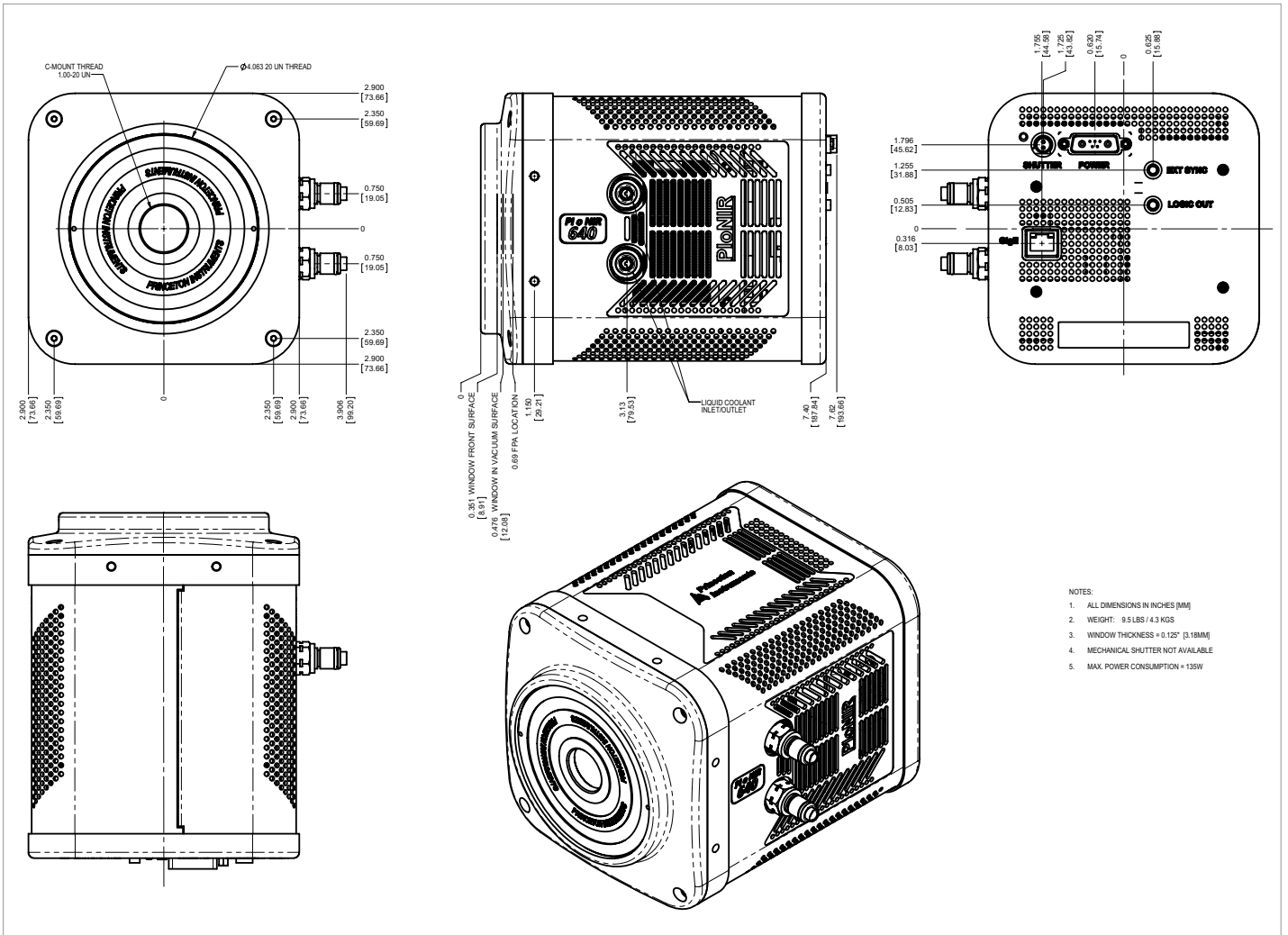

Spectrometer adapter is available upon request.

Application Images

Photoluminescence of a textured solar cell

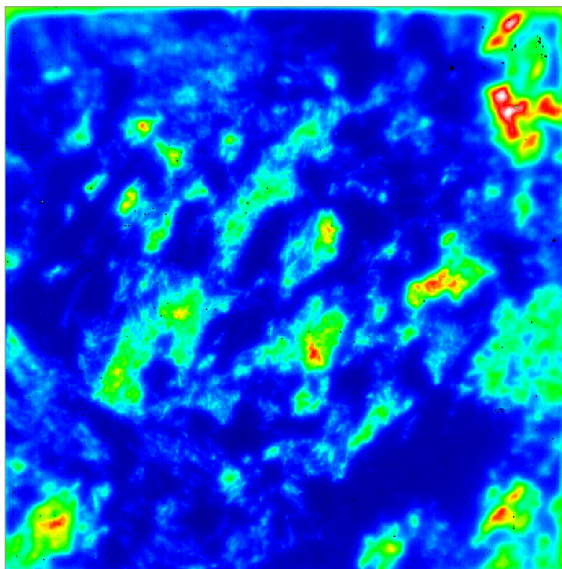
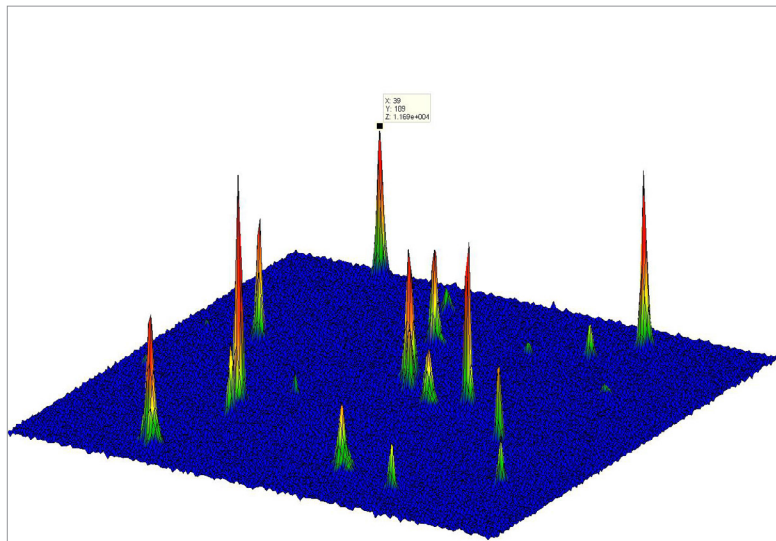
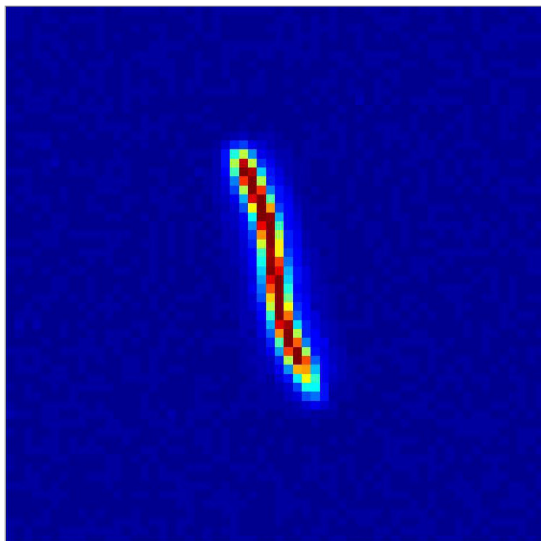

Image courtesy of Dr. Steven Johnson,
National Renewable Energy Laboratory
Golden, CO USA

Single walled nanotube (SWNT)



Images courtesy of Dr. R. Bruce Weisman, Professor of Chemistry
The Richard E. Smalley Institute for Nanoscale Science and Technology
Rice University
Houston, TX USA