

Quad-RO: 4320

2084 x 2084 imaging array | 24 x 24 μm pixels

The Princeton Instruments Quad-RO: 4320 is a fully integrated, low noise, 4-port readout camera designed for indirect imaging of x-rays using phosphor screens. This unique camera design, utilizing Princeton Instruments' state-of-the-art cooling technology, ultra-low noise electronics and a unique fiber-optic design, offers outstanding flexibility for optimizing system performance across a wide range of X-ray energies. The compact design with the industry standard Firewire (IEEE 1394a) interface makes the Quad-RO: 4096 perfect for OEM applications, while software selectable dual speed operations, at 500 kHz or 1 MHz, allow users to optimize camera performance for demanding applications.

FEATURES	BENEFITS
2084 x 2084 imaging array, 24 x 24 μm pixels	Large image area with highest dynamic range and highest sensitivity (70% QE @ 550nm)
1:1 fiberoptic ratio *	Highest sensitivity with distortion and vignetting-free operation
2.4:1 fiberoptic ratio *	Largest affordable field of view (120 mm x 120 mm)
Scientific grade CCD	Low noise, few cosmetic defects, linear response
Low noise electronics	Best performance for demanding low energy X-ray imaging applications
16-bit dual digitizers	Dual-speed digitization allow complete freedom to select between "low noise" for highest signal-to-noise ratio (SNR) or "fast operation" for high frame rate
Software selectable gains	Flexibility to optimize SNR and dynamic range
Thermoelectric cooling	Liquid cooling for vibration and worry free operation, and ease of use
Flexible ROI/binning	Allows faster frame rate and/or sensitivity, 2k x 2k, 1k x 1k and 512 x 512
Electronically balanced 4-output ports	Very uniform image at any intensity level for raw image display
Firewire (IEEE-1394a) interface	Industry standard interface for ease of integration
Renowned WinView software	Offers powerful, easy-to-use software package for acquisition and display, Easy integration for OEM
Linux driver and PVCAM interface	Universal programming interface for easy custom programming and integration
Custom phosphors *	Gd ₂ O ₂ S:Tb Available for 8 keV, 12 keV and 17 keV Resolution of ~50 μm Emission wavelength ~550 nm

* Contact factory for information on fiber-optic ratios and phosphors

Applications:

X-ray microtomography, X-ray phase contrast imaging, industrial & medical imaging, x-ray diffraction, crystallography and electron imaging

SPECIFICATIONS

CCD image sensor	Front-illuminated, scientific-grade, MPP device with ITO technology from Kodak	
CCD format	2084 x 2084 imaging pixels 24 x 24 μm pixels with 100% fill factor 70% QE @ 550nm 50.00 x 50.00 mm CCD image area	
Full well	Single pixel	650 ke- (typical) ; 500 ke- (min)
	Output mode	550 ke- (typical) ; 500 ke- (min)
System read noise	@500 kHz	8 e- rms (typical) - 10 e- rms (max)
	@1 MHz	10 e- rms (typical) - 14 e- rms (max)
ADC speed/bits	500 kHz/ 16 bits and 1 MHz/ 16 bits	
System gain / X-ray energy		
1:1 fiber-optic	~ 93 e- / 8 keV, ~ 140 e- / 12 keV, ~ 195 e- / 17 keV	
2.4:1 taper	~ 14 e- / 8 keV, ~ 24 e- / 12 keV, ~ 34 e- / 17 keV	
Software selectable gains	2.5e-, 5.0e- and 9e- / ADU ; available at all speeds	
Dark Current @ -50 °C	0.01 e- / p / sec (typical); 0.075 e- / p / sec (max)	
Deepest cooling temperature		
Thermoelectric (+5 °C liquid)		
1:1 fiber-optic	-50 °C (typical); -40 °C (guaranteed)	
2.4:1 taper	-50 °C (typical); -40 °C (guaranteed)	
4-port electronics	Four independent A/D converter circuits electronically balanced to < 1 %	
Non-linearity @ 1 MHz	≤ 1 %	
Parallel shift rate	120 μsec	
Thermostating precision	± 0.1 °C (for stable baseline performance)	
I/O signals	OUTPUT: Two BNC connectors - SCAN, READY INPUT: One BNC connector - trigger-in	
Operating environment	+5 °C to +30 °C ambient, < 50% relative humidity	
Certification	CE	
Dimensions	1:1 fiber-optic	6 inches (155 mm) diameter x 9.32 inches (237 mm)
	2.4:1 taper	8.5 inches (215.9mm) diameter x 10.66 inches (270.9mm)
Weight	1:1 fiber-optic	23 lbs (10.5 kg)
	2.4:1 taper	43.5 lbs (19.75 kg)

NOTE: All specifications subject to change

FRAME RATE

		Readout Time	
		@ 1 MHz	@ 500 kHz
Binning	1 x 1	1.37 sec (0.72 fps)	2.45 sec (0.40 fps)
	2 x 2	0.64 sec (1.56 fps)	0.91 sec (1.1 fps)
	4 x 4	0.36 sec (2.77 fps)	0.43 sec (2.3 fps)
	8 x 8	0.25 sec (4.0 fps)	0.30 sec (3.3 fps)

QUANTUM EFFICIENCY CURVE

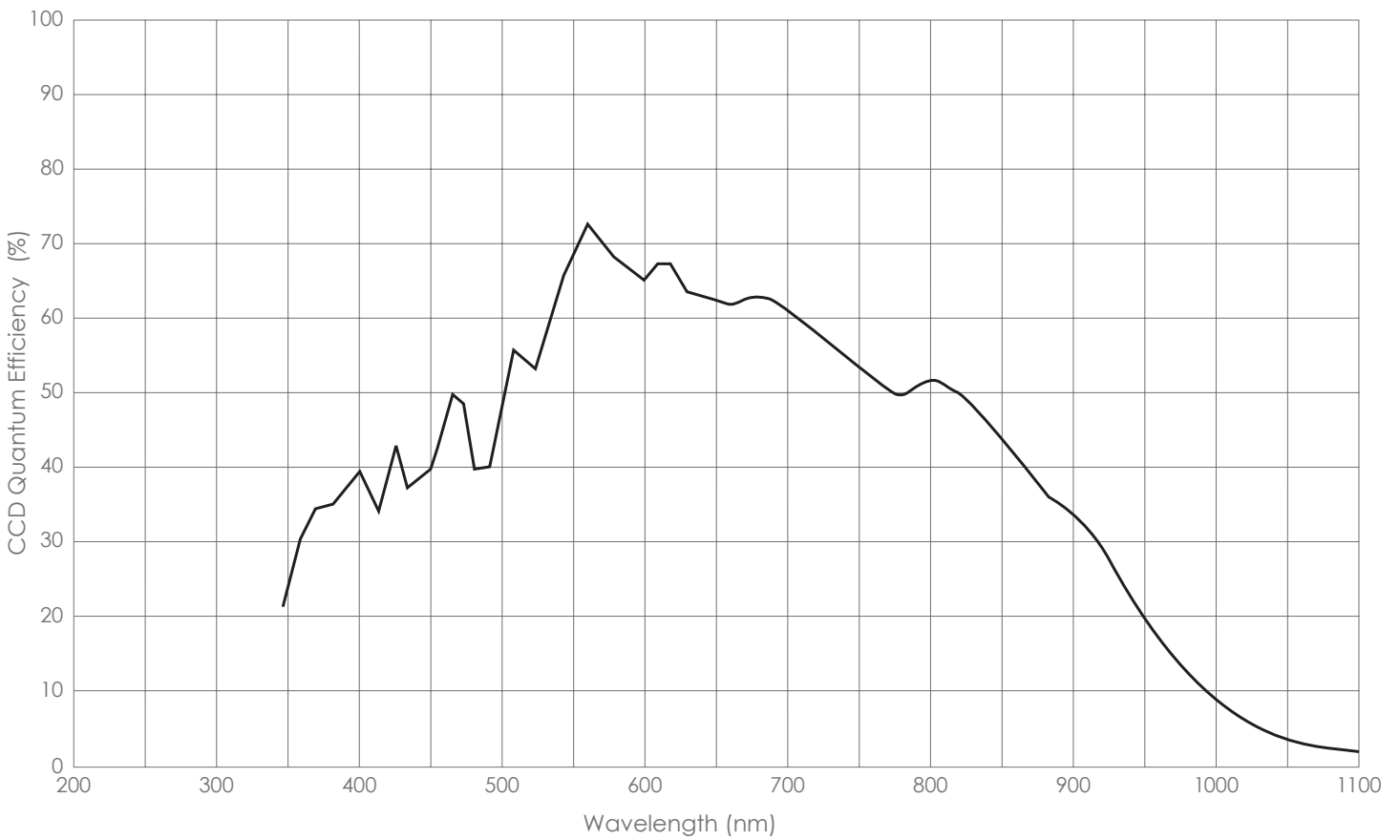

QUAD-RO DRAWING

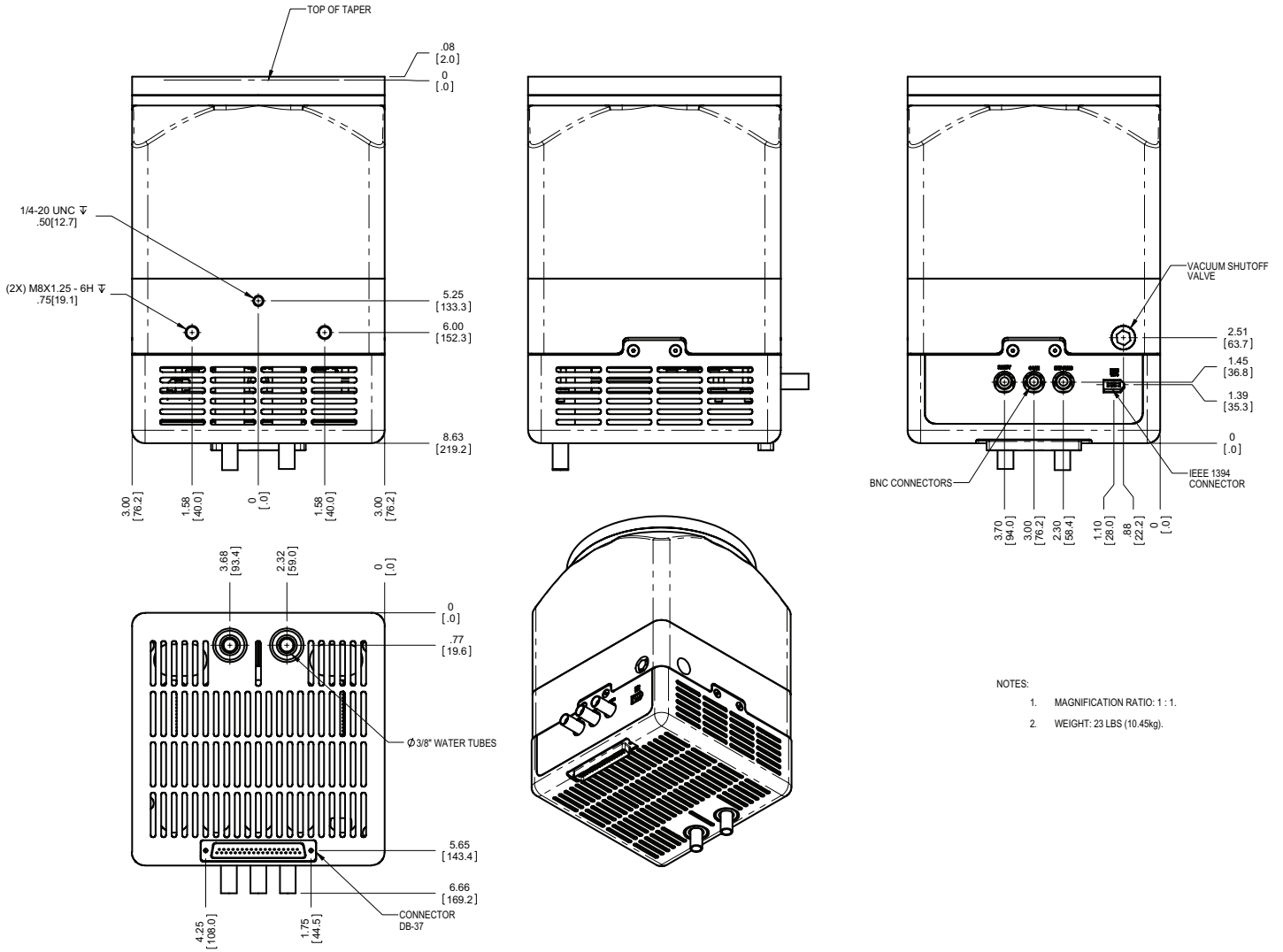

QUAD-RO: 4320 WITH BERYLLIUM WINDOW

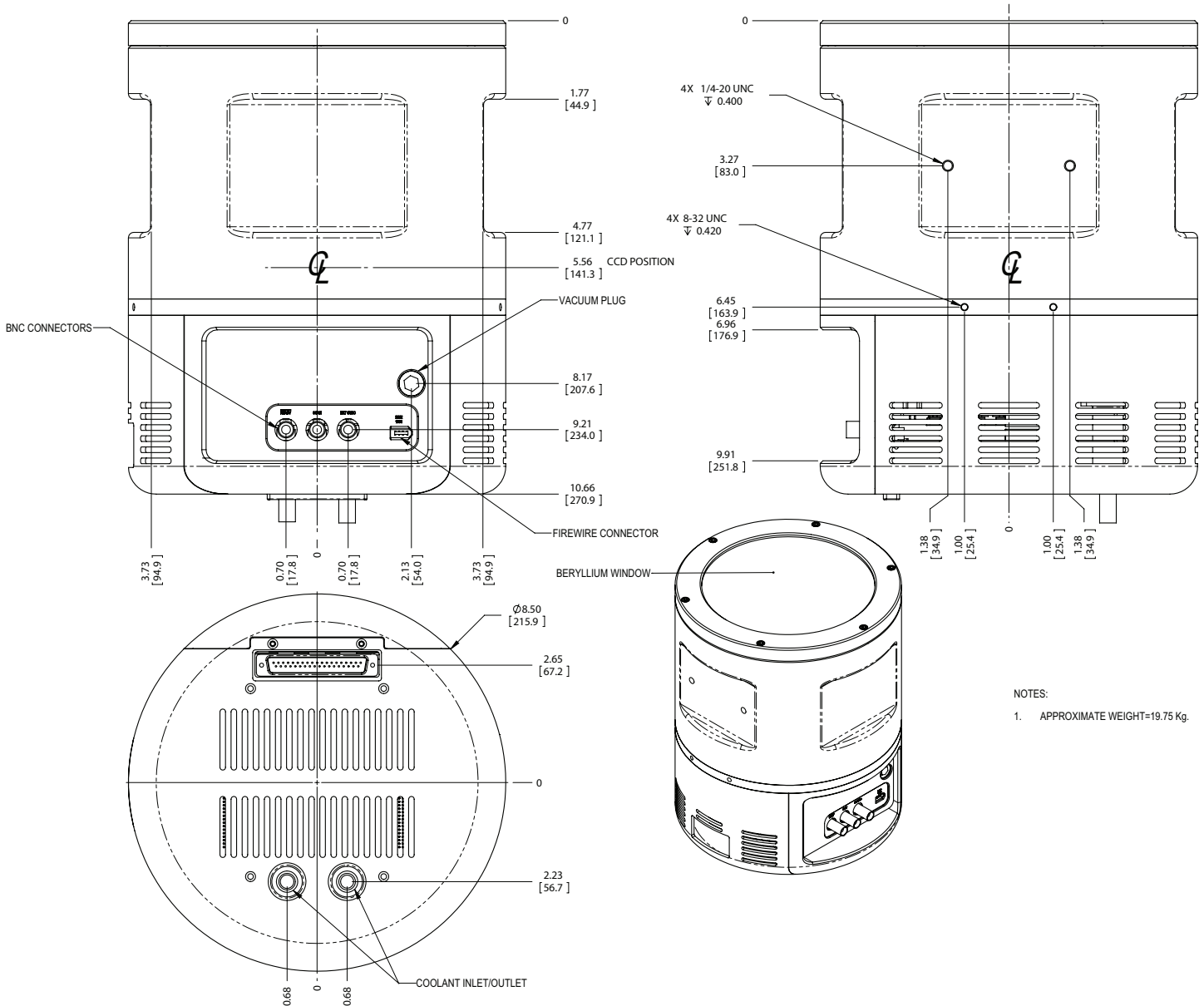

NOTES:
1. APPROXIMATE WEIGHT=19.75 Kg.