



## Advanced PVCAM® Features Circular Buffers and Device Sequencing

© 2001 Roper Scientific, Inc. All rights reserved.

### Introduction

All cameras built by Roper Scientific® support two extremely useful image-acquisition features: circular buffers and device sequencing\*. These powerful functions are enabled by Roper Scientific's exclusive PVCAM (Programmable Virtual Camera Access Method), an easy-to-use universal programming interface for Photometrics- and Princeton Instruments-brand cameras. Circular buffers allow the cameras to operate at their maximum achievable frame rates independently of a host computer, whereas device sequencing offers optimal integration of the cameras with other devices in an experiment.

### Circular Buffers: Concept

In a typical image-acquisition cycle, each image is transferred from the camera via DMA (direct memory access) to the host computer's memory, where the software application is subsequently able to access it (e.g., for display or post-acquisition data-processing purposes). Only after the image transfer is complete will the host computer issue a new command (i.e., a handshake signal) to the camera so that it can begin to receive the next frame. The real-time performance of the entire imaging system is adversely affected by this additional operating-system latency, the size of which depends on the operating system's process load.

Using circular buffers, however, the camera automatically transfers the image data sequentially to a pre-allocated buffer (memory location) in the host computer. When the end of the designated buffer is reached, the data continues to be stored, starting at the beginning of the same buffer (see **Figure 1**). In this scenario, the imaging application simply needs to retrieve the data at any time before the buffer is filled. The camera user has the option to overwrite the buffer before the software application retrieves the data (e.g., live focus) or not to overwrite it (e.g., acquiring a sequence without skipping any frames).

### Circular Buffers: Advantages

Circular buffers offer several advantages over typical image-acquisition cycles, as described in the following sections.

#### Real-time image display

By opting to retrieve and display the most recently stored frame, image data can be displayed in virtually real time. This capability is highly useful for live-mode (focus) operation during setup of an imaging experiment.

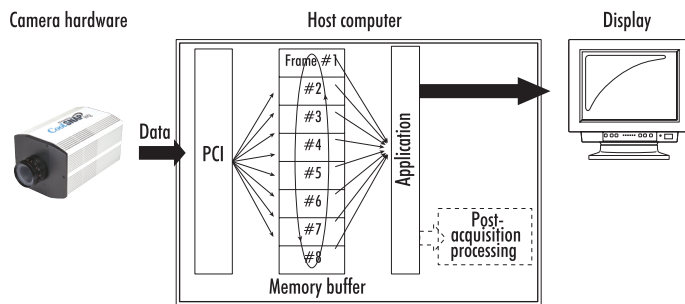

Figure 1. This diagram illustrates the concept of circular buffers.



### *Precise timing*

Since the camera is continuously transferring the data at regular intervals (determined by both the exposure and readout times of the CCD), each frame in a sequence is offset from the previous frame by a precise increment. Because this transfer is independent of the host computer's process load, the feature is very useful in time-critical experiments such as time-resolved imaging.

### *No data-processing overhead*

Because the camera transfers data independently of the software application, data-processing overhead does not affect frame rate. This asynchronous (independent) operation of the camera ensures maximum achievable frame rates.

### *Pre- and post-trigger event information*

Using circular buffers, it is possible to retrieve the images acquired prior to the trigger. Failure analysis, in particular, can benefit greatly from this ability. When a process or component failure occurs, it is often of paramount importance to determine the primary cause of the failure. With circular buffers, the failure itself can be established as a trigger-generating event, one which informs the software application to read out a number of buffered images acquired before and after the event. Observation of biological phenomena, such as the firing of a neuron, can also benefit from the use of circular buffers.

### **Device Sequencing**

In addition to circular buffers, Roper Scientific's PVCAM 2.5.8 introduces another useful feature: device sequencing. Essentially, device sequencing is the concept of synchronizing several devices in real time, generally through the software application. A good example is the synchronization of a CCD camera and a filter wheel. As soon as the camera transfers the data to the buffer, the application is notified by the end-of-frame interrupt, which in turn issues a command to the filter wheel to move to the next position.

Another common way to synchronize devices is via hardware. All Roper Scientific cameras also feature several TTL-level hardware signals that can be used to synchronize / trigger other devices in an experiment.

To learn more about circular buffers and device sequencing, please refer to the Roper Scientific PVCAM 2.5.8 user documentation. This information can be obtained by choosing PPK (under the custom-install option) during the PVCAM 2.5.8 installation.

*\* In order to take advantage of these features, Photometrics-brand cameras require PVCAM 2.5.8 (or later), version 11 (or later) of the PCI firmware, and a software application capable of utilizing circular buffers and device sequencing. Princeton Instruments-brand cameras require only PVCAM 2.5.8 (or later) and a software application capable of utilizing circular buffers and device sequencing to take advantage of these features.*

Contact **Roper Scientific, Inc.** for more information:

3660 Quakerbridge Road Trenton, NJ 08619  
tel: 609.587.9797  
fax: 609.587.1970  
email: [info@roperscientific.com](mailto:info@roperscientific.com)  
web: [www.roperscientific.com](http://www.roperscientific.com)

3440 East Britannia Drive Tucson, AZ 85706  
tel: 520.889.9933  
fax: 520.573.1944  
email: [info@roperscientific.com](mailto:info@roperscientific.com)  
web: [www.roperscientific.com](http://www.roperscientific.com)