



PIXIS-XB: 1300

The PIXIS-XB: 1300 is a family of fully integrated cameras that utilizes a back illuminated, deep depletion CCD for direct detection of X-rays between $< 3\text{keV}$ and 20keV . This highly sensitive, high resolution camera is designed for very low X-ray flux imaging. With $20\ \mu\text{m} \times 20\ \mu\text{m}$ pixels and 100% fill factor, this system provides high spatial resolution. A thin beryllium window in front vacuum-seals the unit for deep cooling, protects the CCD, and reduces background by filtering low-energy X-rays. The thermoelectrically cooled option delivers maintenance-free operation. The software-selectable gains, output amplifiers, and readout speeds offer users highly flexible configuration capabilities to optimize system performance.

FEATURE	BENEFITS
Back-illuminated, deep depletion CCD	Provides very low X-ray flux imaging with higher sensitivity for X-ray energy ranging from $< 3\text{keV}$ to $\sim 5\text{keV}$; provides higher protection than F/I deep depletion CCDs against x-ray damage.
Front-illuminated, deep depletion CCD	Provides very low X-ray flux imaging with higher sensitivity than B/I, deep depletion CCD, for X-ray energy ranging from $\sim 5\text{keV}$ to 20keV
All-metal, hermetic vacuum seals	No out-gassing (as in epoxy seals) which can compromise vacuum performance
Thermoelectric cooling	Air Cooling Water cooling
	Allows maintenance free operation Allows vibration free operation with room temperature, coolant circulation for temperature fluctuation sensitive applications (CoolCUBE II required)
1340 x 1300 imaging array, $20\ \mu\text{m} \times 20\ \mu\text{m}$ pixels	High spatial resolution
Scientific grade CCD	Low noise, few defects, linear response
Low noise electronics	Best performance with high dynamic range
Dual digitizers	Dual-speed digitization allows complete freedom to select between "slow operation" for low noise and highest SNR or "fast operation" for rapid image acquisition
Software selectable system gains	Flexibility to optimize signal-to-noise ratio and dynamic range
Kinetics readout mode	Custom readout mode offers microsecond resolution
USB2.0 data interface, Optional fiber optic interface	Plug-n-play operation; Use it with laptop; Fiber optic interface is ideal for remote operation
WinView/Spec (for Windows XP/7; 32-bit) or LightField™ (for Windows 7; 64-bit)	Powerful, yet easy-to-use software packages for acquisition, display and analysis; LightField offers cutting edge interface, direct to hard drive streaming, time stamping & more
PVCAM/PICAM software interface	Universal programming interface for easy custom programming; PVCAM for Windows XP/7 (32-bit) and Linux; PICAM for Windows 7 (64-bit)
LabView® Scientific Imaging ToolKit (SITK™)	Predefined vis for easy integration of camera controls into large experiment

Applications:

X-ray Spectroscopy, X-ray Photon Correlation Spectroscopy (XPCS), X-ray Intensity Fluctuation Spectroscopy (XIFS), X-ray diffraction and X-ray lithography

SPECIFICATIONS

	PIXIS-XB: 1300R	PIXIS-XB: 1300BR
Features	Front-illuminated, deep depletion CCD. Higher sensitivity in X-ray range from ~ 5 keV to 20 keV.	Back-illuminated, deep depletion CCD. Higher sensitivity in X-ray range from < 3 keV to ~ 5 keV.
CCD Image Sensor	Proprietary CCD, front-illuminated, deep depletion, grade 1, NIMO	Proprietary CCD back-illuminated, deep depletion, grade 1, NIMO
Dark current @ -60° C (e-/p/sec)	0.32 (typical) 0.65 (max)	0.32 (typical) 0.65 (max)
CCD format	1340 x 1300 imaging pixels; 20 μm x 20 μm pixels; 100% fill factor	
Imaging area	26.8 x 26.0 mm (optically centered)	
Deepest cooling temperature	< -70° C (typical), -60° C (guaranteed) with CoolCUBEII liquid circulator < -65° C (typical), -55° C (guaranteed) with air	
Thermostating precision	±0.05° C	
Cooling method	Thermoelectric air or liquid cooling (CoolCUBE II liquid circulator available)	
Full well:	Single pixel Output node	250 ke- (typical), 200 ke- (min) 1000 ke- (typical), 800 ke- (min)
ADC speed/bits	100kHz/16-bit and 2MHz/16-bit	
System read noise	@100 kHz @2 MHz	3.0 e- rms (typical), 5 e- rms (max) 9.0 e- rms (typical), 15 e- rms (max)
Vertical shift speed	27 μsec/row (programmable)	
Non-linearity	<1% @ 100 kHz	
Software selectable gains	1, 2, 4 e- (high sensitivity); 4, 8, 16 e- (high capacity); available at all speeds	
Operating systems supported	Windows XP/7 (32-bit), Windows 7 (64-bit) and Linux	
Data interface	USB2.0 (5m interface cable provided); Optional Fiberoptic interface is available for remote operation	
I/O signals	Two MCX connectors for programmable frame readout, shutter, trigger in	
Operating environment	+5 to +30° C non-condensing	
Certification	CE	
Dimensions / Weight	16.59 cm (6.53") x 11.81 cm (4.65") x 11.38 cm (4.48") (L x W x H) / 2.27 kg (5 lbs)	

NOTE: All specifications subject to change

FRAME RATE

	Readout Time		
	@ 2 MHz	@ 100 kHz	
Binning	1 x 1	0.93 sec	16.0 sec
	2 x 2	0.402 sec	4.762 sec
	8 x 8	0.12 sec	0.491 sec

QE DATA

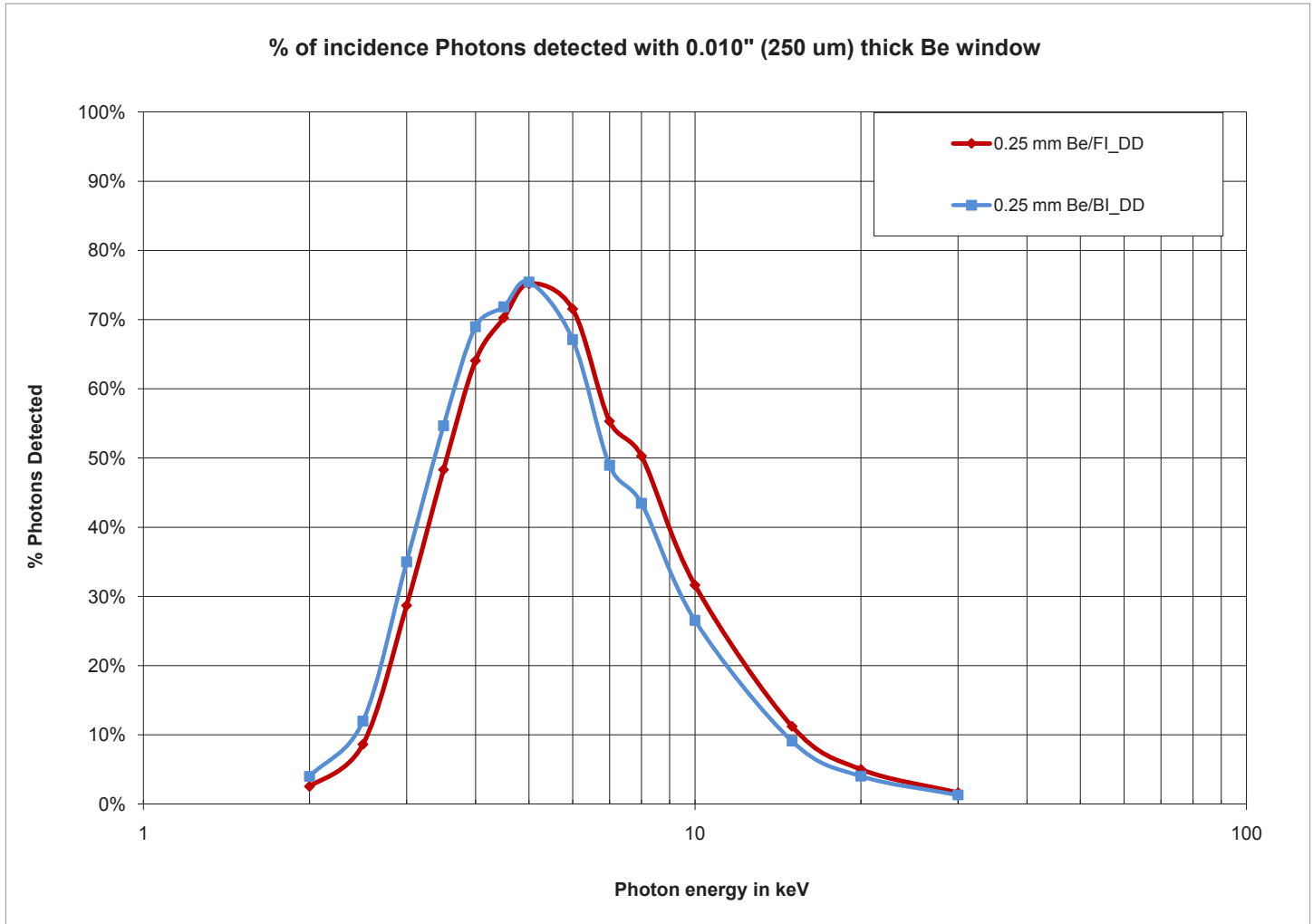

OUTLINE DRAWING

PIXIS-XB: 1340 X 1300BR AIR COOLED

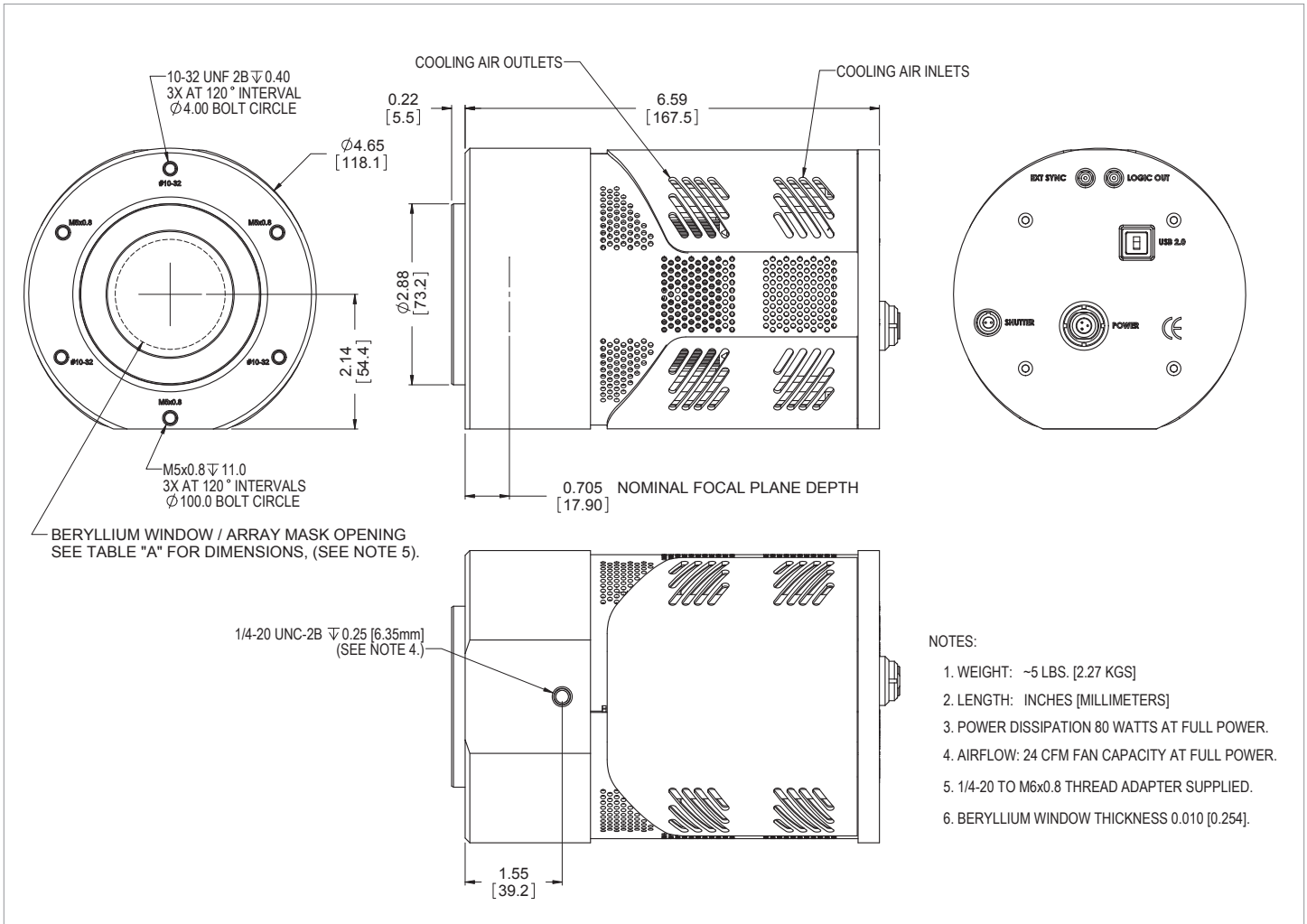

OUTLINE DRAWING

PIXIS-XB: 1340 X 1300BR LIQUID COOLED

